

## Testing Solutions for Containment Systems





Installed Absolute® (HEPA) filters should be field tested to verify they are performing as specified. Each Absolute filter will have passed factory performance testing to verify that they perform to industry standards and meet the filter model's rated efficiency. However, between that factory testing and the installation into a filter housing, much can happen.

Damage can occur during shipping, or installation and handling, even by experienced and trained personnel. Once installed, the filter-to-mounting-frame seal interface may have some by-pass. These and other factors can result in an installed filter element that no longer maintains its minimum required efficiency.

There are various test procedures to determine whether an installed filter bank performs per its designed intent. Of these test procedures, there are basically three commonly used in the field. They are:

1. Overall average efficiency of the entire filter bank test
2. Individual filter average efficiency test
3. Filter scan test

All these field tests generally involve four main elements (See illustration "There are 4 main elements to filter testing." on page 3):

1. Test aerosol injection
2. Aerosol mixing
3. Aerosol uniformity at filter
4. Downstream sampling

Each of these elements is important in order to achieve a satisfactory field test.



- Safe to use
- Validated designs meet code requirements
- Accurate and repeatable results
- Non-intrusive filter testing solutions

## OVERALL FILTER BANK TESTING

### What about ten duct diameters?

A rule of thumb maintains that injecting test aerosol 10 duct diameters upstream of a filter is adequate for thorough mixing to occur. This rule is referenced by many engineering publications. However, there is evidence this is not true in some situations. Typically for the "10 duct diameter" rule to work, the duct run should be straight and not interrupted by elbows or other obstructions. In practice, having the necessary mechanical space to achieve this mixing is rare. Typically, filter housings are placed in very tight spaces. Even 10 straight duct diameters may not achieve the necessary mixing desired. Regardless of the duct run length, the upstream face of the filter bank must be validated to have consistent air/aerosol uniformity.

### There are 4 main elements to filter testing.

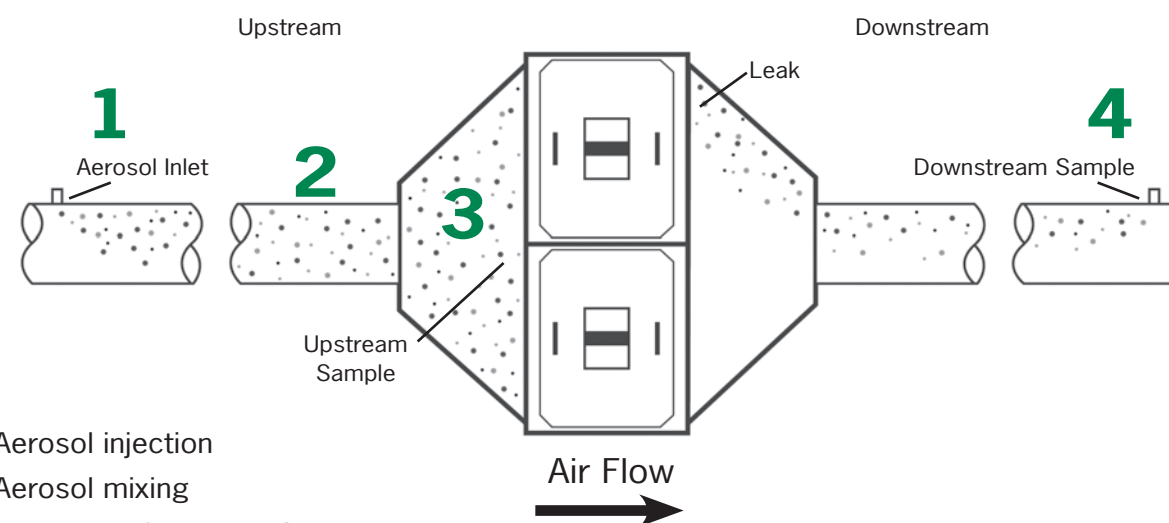

1. Aerosol injection
2. Aerosol mixing
3. Aerosol uniformity at filter
4. Downstream sampling

**Overall filter bank test.** This test method is the simplest and the least expensive. A test aerosol is injected upstream of the filter bank. The injection point is critical because the test aerosol must be thoroughly mixed with the process stream. This mixed aerosol is sampled just upstream of the filter bank. For the test to be valid, the air/aerosol mixture must be uniform across the face of the filter bank. There are many factors that may affect the in-place test results of installed Absolute® filter banks.

The following have a major effect on the measured Absolute bank efficiency:

- airflow rates
- prefilter efficiency
- prefilter loading
- location of the injection point
- method of injection
- upstream sample line location and sample method
- downstream sample line location and sample method.

In a paper presented at the 29<sup>th</sup> Nuclear Air Cleaning Conference, it concluded "...it is possible to have eight different test results without changing the size or location of the leak. Test results ranging from 'passing' to 'failing' can be obtained on the same system depending on the test technique and methodology." This paper highlights one of the deficiencies inherent to this test method, namely test consistency or repeatability.

## OVERALL EFFICIENCY TEST SOLUTIONS

Camfil overall efficiency test sections:

- Are specially designed to attach directly to other Camfil containment modules ensuring complete system integrity from a single source manufacturer
- Are manufactured from the same materials as the containment section
- Are tested to the same design criteria as the other containment sections.
- Allow individual filter testing
- Are designed to protect test technicians from potential exposure to the contaminated airflow
- Incorporate a unique cross-sampling tube array that ensures overall filter efficiency detection for each filter located within the bank.
- Features a stationary mixing system that ensures the test condition matches the process conditions.
- Have sampling ports furnished to connect operator-supplied testing equipment.
- Are validated and documented to operate per ASME N-510 (Testing of Nuclear Air Treatment Systems) and the ASME AG-1 Code requirements

Absolute® filter test housings have been used successfully in nuclear applications for more than 30 years. While these test housings can test individual HEPA filter elements, the result is

an average measure of the penetration across the face area of each filter.

Camfil Overall Efficiency Test sections are utilized whenever injection of a test aerosol at a single point does not result in the required distribution of the agent uniformly across the face of the filter being tested or where single point sampling on the downstream of the filter does not allow the space for uniform mixing. Test sections provide a validated means to simulate ideal mixing conditions and provide a much greater likelihood of identifying leakage that could otherwise be missed from single point sampling due to limited access to the ductwork. Several publications (e.g. DOE-HDBK-1169-2003, Nuclear Air Cleaning Handbook) maintain 10 duct diameters is adequate for thorough air/aerosol mixing to occur but there is evidence that this is not true in some situations. Regardless, common testing protocols require injection and downstream sampling to occur at least 10 straight duct diameters from the filter bank. This protocol is designed to ensure adequate mixing of the test aerosol prior to the filter bank. The downstream requirement is usually sufficient to adequately mix the filter discharge to obtain a test sample. However, providing long duct runs up and downstream of filter banks is not always practical. Camfil test sections are designed and validated to replicate the mixing conditions of 10 duct diameters in a short length. In addition, these test sections can sample each HEPA filter in a bank.

## WHY A FIXED AEROSOL MIXING (BAFFLE) SYSTEM?



Would you take an eye exam wearing glasses? Of course not. Why? Because the results of your examination would not represent the condition of your eyes. To reduce system pressure drop and subsequent operating costs, some manufacturers furnish swing-away or rotating aerosol mixing systems. As a sustainable company, Camfil does not take excessive pressure drop lightly. The reason for adding a test section into a housing assembly is to ensure uniform aerosol distribution at the face of the filter element. If altering the internal airflow for testing creates the desired aerosol uniformity, why should this condition only exist in the "test mode?"

The test condition should equal the operating condition within a filter housing. Otherwise the filters may not load uniformly, resulting in premature change outs. While we respect the intent (i.e. energy savings), having a test condition that is different from the operating condition is not accurate and gives a false impression of the condition of the filter element.

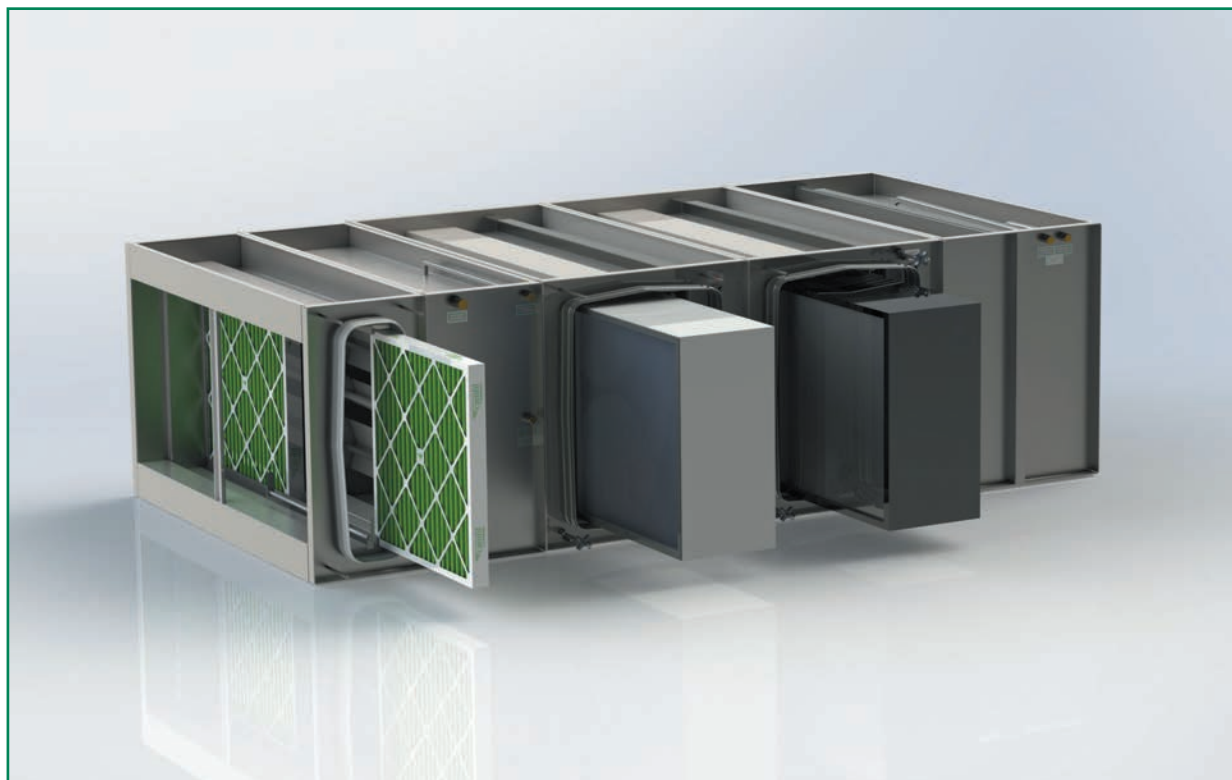

### Nuclear Series and Professional Series Containment Solutions

Camfil manufactures two series of Containment housings. The primary difference between these two series is the documentation related to nuclear quality assurance requirements. We use the same welders who have been qualified per the American Society of Mechanical Engineers (ASME) nuclear code, the same grades of stainless steel, and we qualify every testing housing section per the rigorous nuclear code.

The Nuclear Series is designed and fabricated in strict accordance with the latest version of ASME AG-1 nuclear code. All quality assurance procedures are in accordance with ASME NQA-1.

While the Professional Series has the same pedigree as the Nuclear Series, this Series is designed to more closely align with the requirements of the biosafety industry. The Homeland Security and Healthcare industries can also benefit from the features of this Series.



There are five different overall efficiency test section models, each with a specific function.

**Upstream Injection Test Sections:** TSU – Injection (Nuclear Series)  
PTU – Injection (Professional Series)

Also known as an INJECTION section. This section is typically located upstream of the Absolute® filter bank to be tested. It is designed to inject a test aerosol, mix the aerosol and take a reference sample of the air/aerosol mixture.

**TSU – Injection (Nuclear Series)**

This TSU injection test section is modular and aligns with the entire filter housing system. This housing injects challenge particulate upstream of each individual filter element, reducing the mass of challenge particulate required to test an entire filter bank. This testing section may be used with the following Camfil testing sections: TSC | TSD | PTD

**TSU**

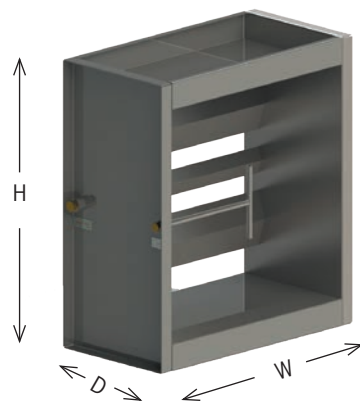

Standard Size	Number of Injection Ports	Number of Sampling Ports	TSU (Injection Test Sections)			
			Height (inches)	Width (inches)	Depth (inches)	Shipping Weight (pounds)
1 x 1	1	1	30	27	14	57
1 x 2	2	2	30	51	14	97
1 x 3	3	3	30	75	14	138
2 x 1	2	2	60	27	14	87
2 x 2	4	4	60	51	14	143
2 x 3	6	6	60	75	14	201
3 x 1	3	3	90	27	14	117
3 x 2	6	6	90	51	14	189
3 x 3	9	9	90	75	14	264
4 x 1	4	4	120	27	14	147
4 x 2	8	8	120	51	14	235
4 x 3	12	12	120	75	14	327

**PTU – Injection (Professional Series)**

The PTU is installed in the inlet duct (typically downstream of the inlet isolation damper) and injects challenge particulate across the entire face of the filter bank. This testing section may be used with the following Camfil testing sections: TSC | PTD | TSD

**PTU**

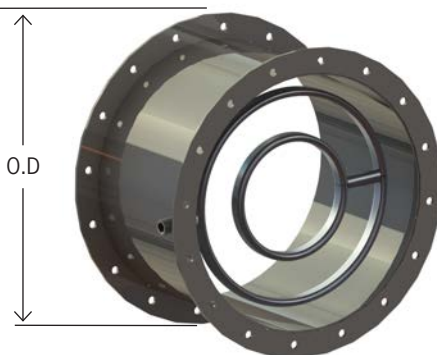

Dimensions - PTU						
Nominal Size	Inside Diameter (inches)	Flange O.D. (inches)	Bolt Circle (inches)	Number of Holes	Bolt Hole Diameter (inches)	Weight (pounds)
*	*	*	*	*	7/16	*
14	14	17	15.5	16		25
20	20	23	21.5	20		35
*	*	*	*	*		*

\* Contact factory

**TSD**

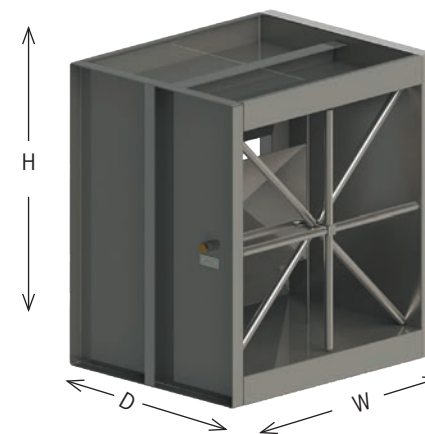

Standard Size	Number of Injection Ports	Number of Sampling Ports	TSD (Injection Test Sections)			
			Height (inches)	Width (inches)	Depth (inches)	Shipping Weight (pounds)
1 x 1	0	1	30	27	22	165
1 x 2	0	2	30	51	22	270
1 x 3	0	3	30	75	22	375
2 x 1	0	2	60	27	22	285
2 x 2	0	4	60	51	22	480
2 x 3	0	6	60	75	22	660
3 x 1	0	3	90	27	22	410
3 x 2	0	6	90	51	22	685
3 x 3	0	9	90	75	22	945
4 x 1	0	4	120	27	22	535
4 x 2	0	8	120	51	22	895
4 x 3	0	12	120	75	22	1230

**PTD – Sample (Professional Series)**

The PTD is installed in the outlet duct (typically upstream of the outlet isolation damper) and samples challenge particulate from the filter bank. This testing section may be used with the following Camfil testing sections: TSU | PTU | TSC

**PTD**

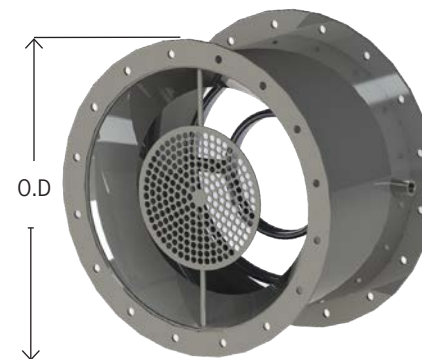

Dimensions - PTD						
Nominal Size	Inside Diameter (inches)	Flange O.D. (inches)	Bolt Circle (inches)	Number of Holes	Bolt Hole Diameter (inches)	Weight (pounds)
*	*	*	*	*	7/16	*
14	14	17	15.5	16		27
20	20	23	21.5	20		40
*	*	*	*	*		*

\* Contact factory

**Overall Efficiency Test Sections: TSC – Injection / Sample (Nuclear Series)**

**TSC – Injection / Sample (Nuclear Series)**

This TSC sample test section is modular and aligns with the entire filter housing system. If a filter housing assembly includes more than one HEPA filter bank in series, a combination housing will be required between those filter sections. As its name implies, a combination test section performs the function of both the TSU and TSD in a single section. This testing section may be used with the following Camfil testing sections: TSU | PTU | TSD | PTD

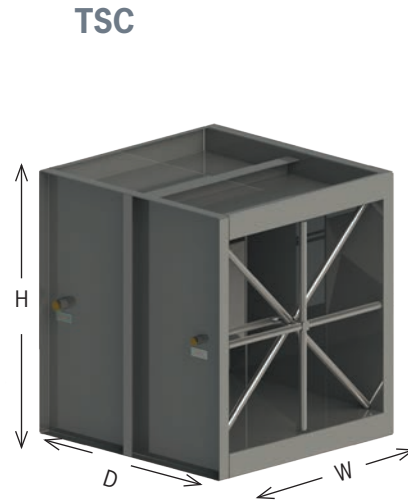

Standard Size	Number of Injection Ports	Number of Sampling Ports	TSC (Injection/Sample Test Sections)			
			Height (inches)	Width (inches)	Depth (inches)	Shipping Weight (pounds)
1 x 1	1	1	30	27	28	215
1 x 2	2	2	30	51	28	360
1 x 3	3	3	30	75	28	505
2 x 1	2	2	60	27	28	380
2 x 2	4	4	60	51	28	645
2 x 3	6	6	60	75	28	900
3 x 1	3	3	90	27	28	545
3 x 2	6	6	90	51	28	930
3 x 3	9	9	90	75	28	1295
4 x 1	4	4	120	27	28	710
4 x 2	8	8	120	51	28	1210
4 x 3	12	12	120	75	28	1690

**SafeScan Filter Scanning Test Sections**

Filter Scanning Test Sections. For certain filtration solutions (primarily in the biosafety industry), assurance of overall filter performance is not enough. The contaminants in these applications may be so dangerous that even a pinhole leak would jeopardize the application's integrity. Camfil scan test sections allow scan testing of individual filters to ensure that each filter element in a bank is leak free. Scan test sections are utilized whenever scan testing of installed Absolute® filters is required. Camfil offers two styles of filter scanning devices: 1. Hand operated and 2. Automated.



No more bags! Antiquated methodology that has not changed in over 40 years is gone.

**SafeScan-M (Manual)**

SafeScan-M is the industry's first non-intrusive manual filter scanning solution. Loss of containment due to a torn or loose scanning bag is eliminated. Accidental probe contact with the HEPA filter media is eliminated. Using a photometer or portable particle counter, the test technician can safely scan test the installed filter (even challenge the filter seal integrity). Please note that manually scanning very high flow Absolute® filters (like the Filtra 2000) is not practical or recommended. Properly scanning these filter types requires scanning speeds much slower than that required for standard and high capacity HEPA filters. If very high flow Absolute® filters are required or specified, select the SafeScan-A scan section.

Camfil SafeScan-M non-intrusive test sections:

- Are specially designed to mount directly to other Camfil containment modules ensuring complete system integrity from a single source manufacturer
- Are manufactured from the same materials as the containment section
- Are tested to the same design criteria as the other containment sections.
- Allow individual filter testing
- Are designed to protect test technicians from potential exposure to the contaminated airflow
- Incorporate patented scanning technology designed to scan the entire face of the tested filter element, including the sealing surface interface
- Have quick disconnect sampling fittings
- Are validated and documented to operate per ASME N-510 (Testing of Nuclear Air Treatment Systems) and the ASME AG-1 Code requirements. Test sections are available in modules up to three filters wide.
- Test Sections are available in modules up to three filters wide.

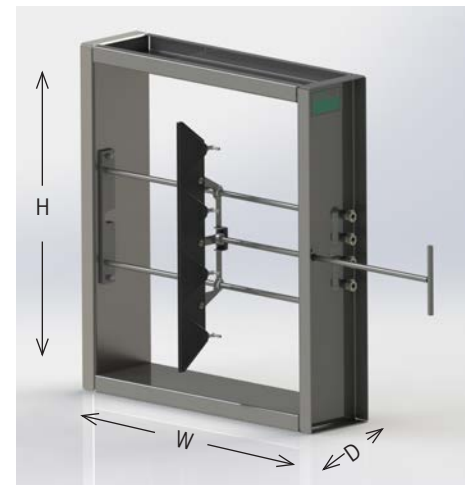

Standard Size	SafeScan-A (Automated Scan Test Section)			
	Height (inches)	Width (inches)	Depth (inches)	Shipping Weight (pounds)
1 X 1	30	27	7	46
1 X 2		51		60
1 X 3		75		67
2 X 1	60	27		92
2 X 2		51		120
2 X 3		75		134
3 X 1	90	27		138
3 X 2		51		180
3 X 3		75		201
4 X 1	120	27		184
4 X 2		51		240
4 X 3		75		268

**SafeScan-A (Automated)**

Camfil SafeScan-A test sections are the most accurate and reliable field testing device available for a containment filter assembly. The Camfil SafeScan-A mechanically-driven non-intrusive filter scanning solution was designed to overcome many of the risks associated with hand-operated scanning. Like all Camfil test sections, SafeScan sections facilitate in-place testing without personnel exposure to the inside of the filter housing.

Camfil SafeScan-A non-intrusive mechanical test sections:

- Are specially designed to mount directly to other Camfil containment modules ensuring complete system integrity from a single source manufacturer
- Are manufactured from the same materials as the containment section
- Are tested to the same design criteria as the other containment sections.
- Allow individual filter testing
- Are designed to protect test technicians from potential exposure to the contaminated airflow
- Incorporate patented mechanical scanning technology designed to scan the entire face of the tested filter element, including the gasket interface.
- Have color-coded and mechanically-keyed quick disconnect sampling fittings furnished to connect to a Camfil Scanning Control System.
- Have a quickly coupled mechanical drive interface connection.
- Are validated and documented to operate per
  - A. IEST-RP-CC034.2, HEPA and ULPA Filter Leak Tests
  - B. EN1822-4:2000, Unidirectional High efficiency particulate air filters (HEPA and ULPA) –Part 4: Determining leakage of filter element (Scan Method)
  - C. ISO/FDIS 14644-3:2004(E): Cleanrooms and associated controlled environments – Part 3: Test methods
- Available in modules up to three filters wide.

As noted above, the SafeScan-A includes mechanically driven sensing probes. Operating a SafeScan-A test section requires a Camfil CamControl system or the Motion Control Lite (also called “MC Lite”). The most cost effective and simple solution is to use the MC Lite unit to drive the scan assembly. In addition to the MC Lite unit, this option would require the filter testing technician to use all the equipment normally used for a manual scan test (i.e. photometer, aerosol generator, etc.). The advantage is the technician would not have to manually move the scan probe while working through a bag. It is much easier, safer and the results are more reliable and repeatable using our non-intrusive automated scan section as compared to a hand operated scan test sections.

The CamControl option is a fully automated control and test equipment package which does all the testing, data acquisition, and reporting automatically once you make all the connections to our containment systems. In addition to scan testing you are able to conduct pressure decay testing, and average efficiency testing. This unit is more expensive than a MC Lite but is completely secure, self-contained, and offers significant advantages to users who have many containment systems to test on their site. Camfil can train and certify technicians on how to use this valuable piece of equipment. Typically, we go to the site to conduct an initial start-up and training when these systems are purchased.

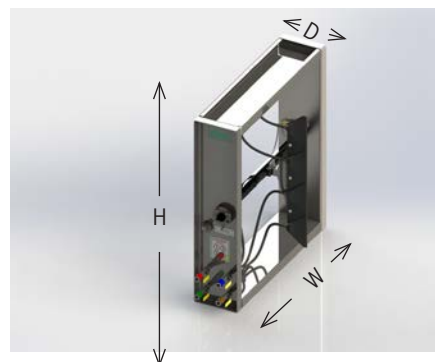

Standard Size	SafeScan-A (Automated Scan Test Section)			
	Height (inches)	Width (inches)	Depth (inches)	Shipping Weight (pounds)
1 X 1	30	27	7	46
1 X 2		51		60
1 X 3		75		67
2 X 1	60	27		92
2 X 2		51		120
2 X 3		75		134
3 X 1	90	27		138
3 X 2		51		180
3 X 3		75		201
4 X 1	120	27		184
4 X 2		51		240
4 X 3		75		268

**SafeScan-M and SafeScan-A UPGRADE Kits**

As the SafeScan technology has matured, owners of existing “hand-in-the-bag” scanning systems desire its safety and reliable testing results. To address this need, Camfil offers SafeScan technology UPGRADE kits. For owners of such systems, these upgrade kits fit into the access ports and convert filter scanning to the SafeScan solutions. Available as a manual or automated system, the SafeScan UPGRADE kit will upgrade a filter system to the same high standards enjoyed by system owners who currently use SafeScan.

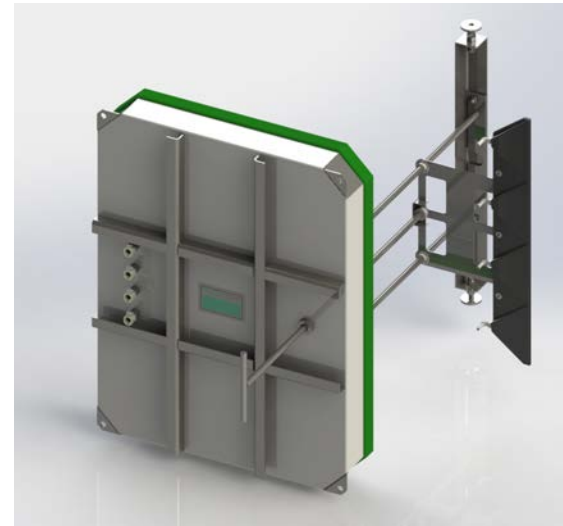

Camfil CamContain SafeScan-M UPGRADE

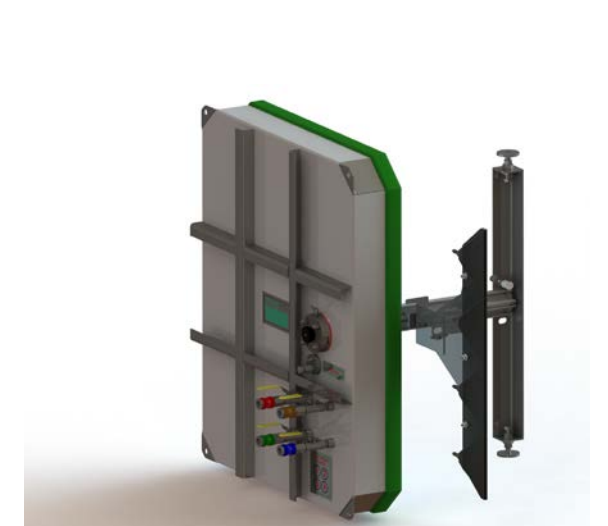

Camfil CamContain SafeScan-A UPGRADE

**What if I have HEPA filters and carbon adsorbers in the same filter train?**

Some systems include Absolute® filter and carbon adsorbers in the same filter train. Is a separate test section in series required for a filter and adsorber? No. If a system has an Absolute® filter followed by a carbon adsorber, the recommended train would be: TSU | HEPA | Carbon | TSD (for Nuclear Series housings) or PTU | HEPA | Carbon | PTD (for Professional Series). The reason is that the challenge agents for HEPA filters and carbon adsorbers flow through each other. DOP (or other aerosols) is not captured by carbon and the reverse is true for carbon adsorber challenge agents.

**Test Aerosols**

Absolute® filters and carbon adsorbers are challenged with different test agents or aerosols. In the past, Di-Octyl Phthalate (DOP) has been used to challenge filter elements. DOP is essentially oil that is heated to create a sub-micronic smoke. The DOP that passes through the filter is measured and compared to the upstream of the filter element. The resultant ratio is the overall penetration of the tested filter element. Due to concerns that Di-Octyl Phthalate may have carcinogenic properties, it has been replaced by alternative products. Interestingly, the abbreviated name (DOP) has been retained - now signifying Dispersed Oil Particulate. Refrigerants are used to test carbon adsorbers. The Institute of Environmental Science and Technology (IEST) has published recommended practices (IEST-RP-CC008.2) that discusses adsorber testing practices. The interesting phenomenon is that challenge agents for filters pass through adsorbers and vice versa. In this way, Absolute filters and carbon adsorbers can be challenged with the same housing.





# CamContain Testing Solutions

A Guide

## **CAMFIL is the world leader in air filters and clean air solutions.**

Camfil is the global industry leader in clean air solutions with 50+ years of experience. Our solutions protect people, processes and the environment to benefit human health, increase performance, and reduce and manage energy consumption. Twenty-three manufacturing plants, six R&D sites and over 65 local sales offices worldwide provide service and support to our customers. The Camfil Group is headquartered in Sweden but more than 95% of sales are international. The Group has around 3,500 employees and sales approaching one billion dollars.

1 North Corporate Drive | Riverdale, NJ 07457  
Phone: 973.616.7300 | Fax: 973.616.7771  
camfil@camfil.com  
www.camfil.com

[www.camfil.com](http://www.camfil.com)

For further information please contact your nearest Camfil office.